



COSMEC[®]

**NR & SPECIAL MACHINES
PRODUCTION PRESENTATION**



THE FACTORY



SINCE 1952



42.000 M2 LAND AND 20.000 M2 FACILITIES



NR 3216 2P
2 PALLETIZED TABLES
1600 X 1600 EACH 2 HEADS

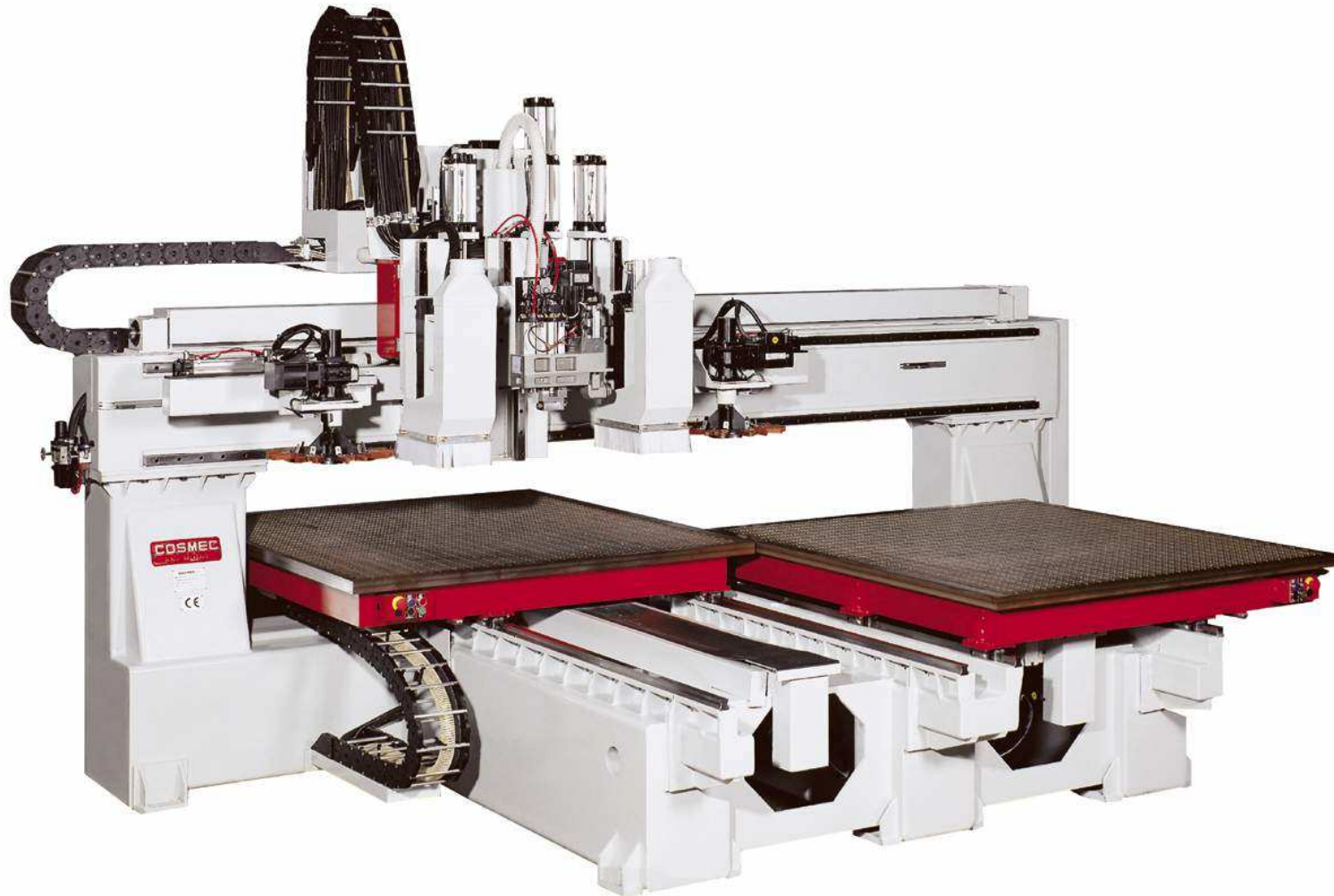



NR 3216 2P
2 PALLETIZED TABLES
1600 X 1600 EACH
5 AXIS HEAD 1200 mm «Z»

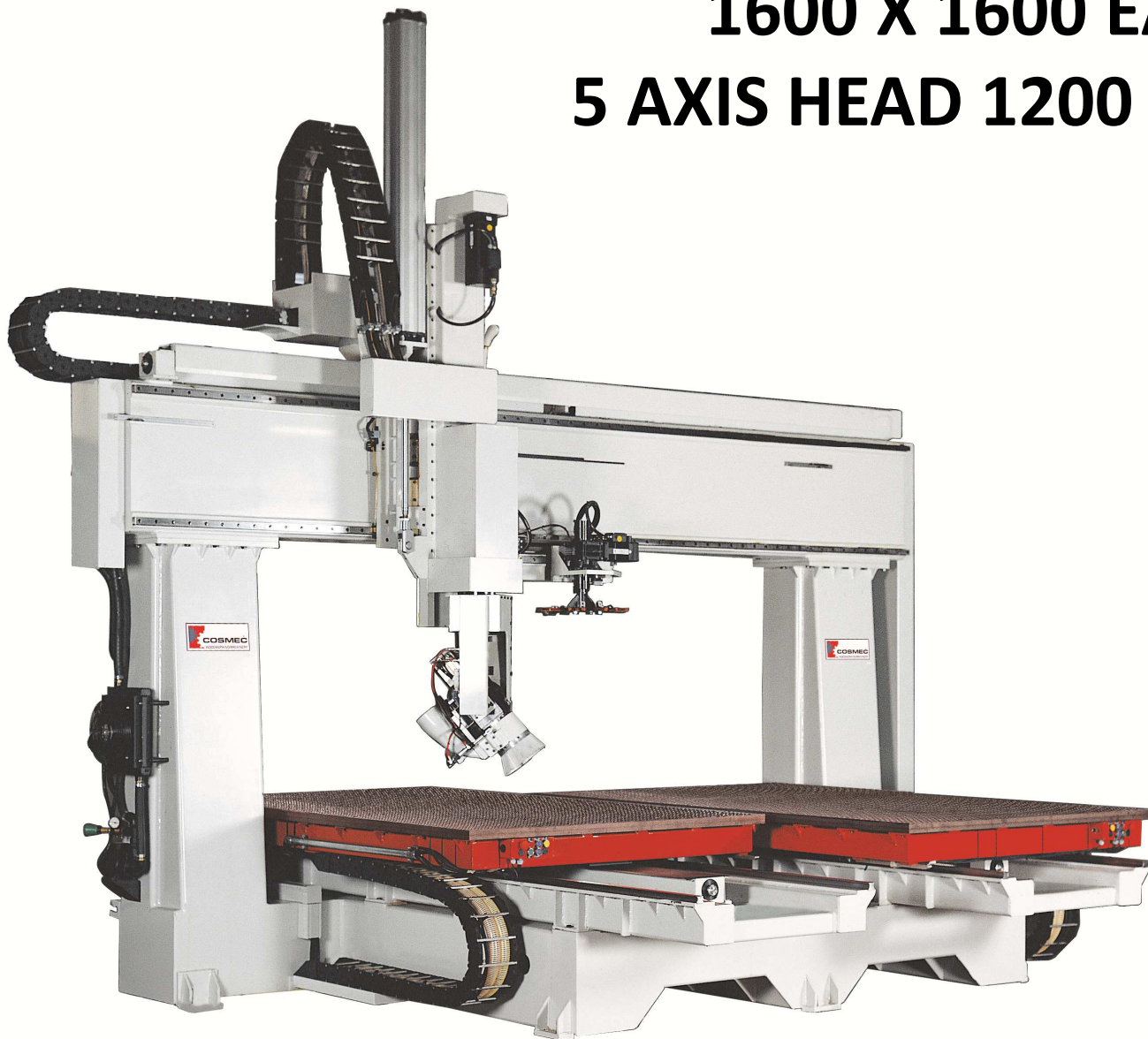



CONQUEST 255 – 515 – 715 «Z» 1000





CONQUEST GANTRY AND CANTILEVER WITH MIXED TABLE: POD & RAILS AND NESTING

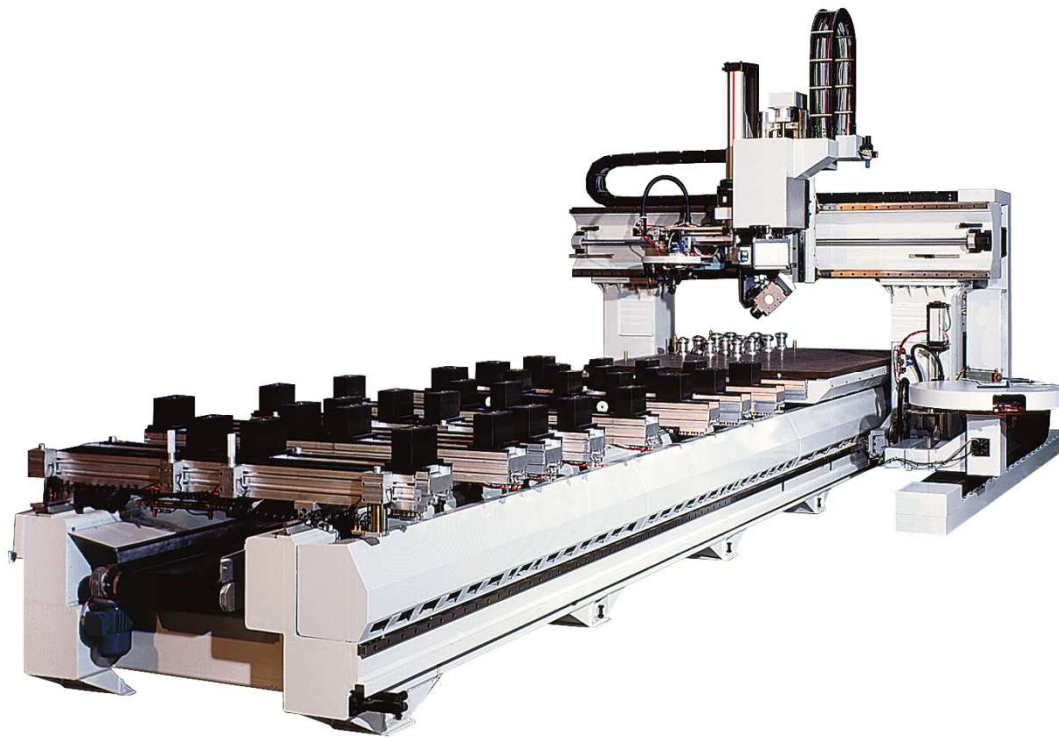



CONQUEST 3200 – 8200 «RIDE» WITH HEADS ON BOTH SIDES OF THE GANTRY

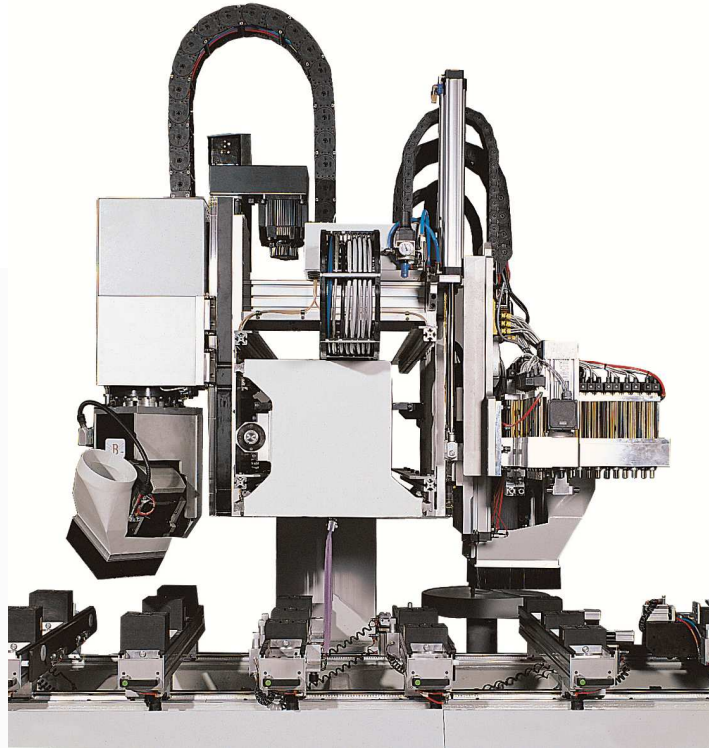



NR 3216 1 TABLE WITH PODS & RAIL

3 AXIS + HORIZONTAL GROUP + 360° SAW UNIT

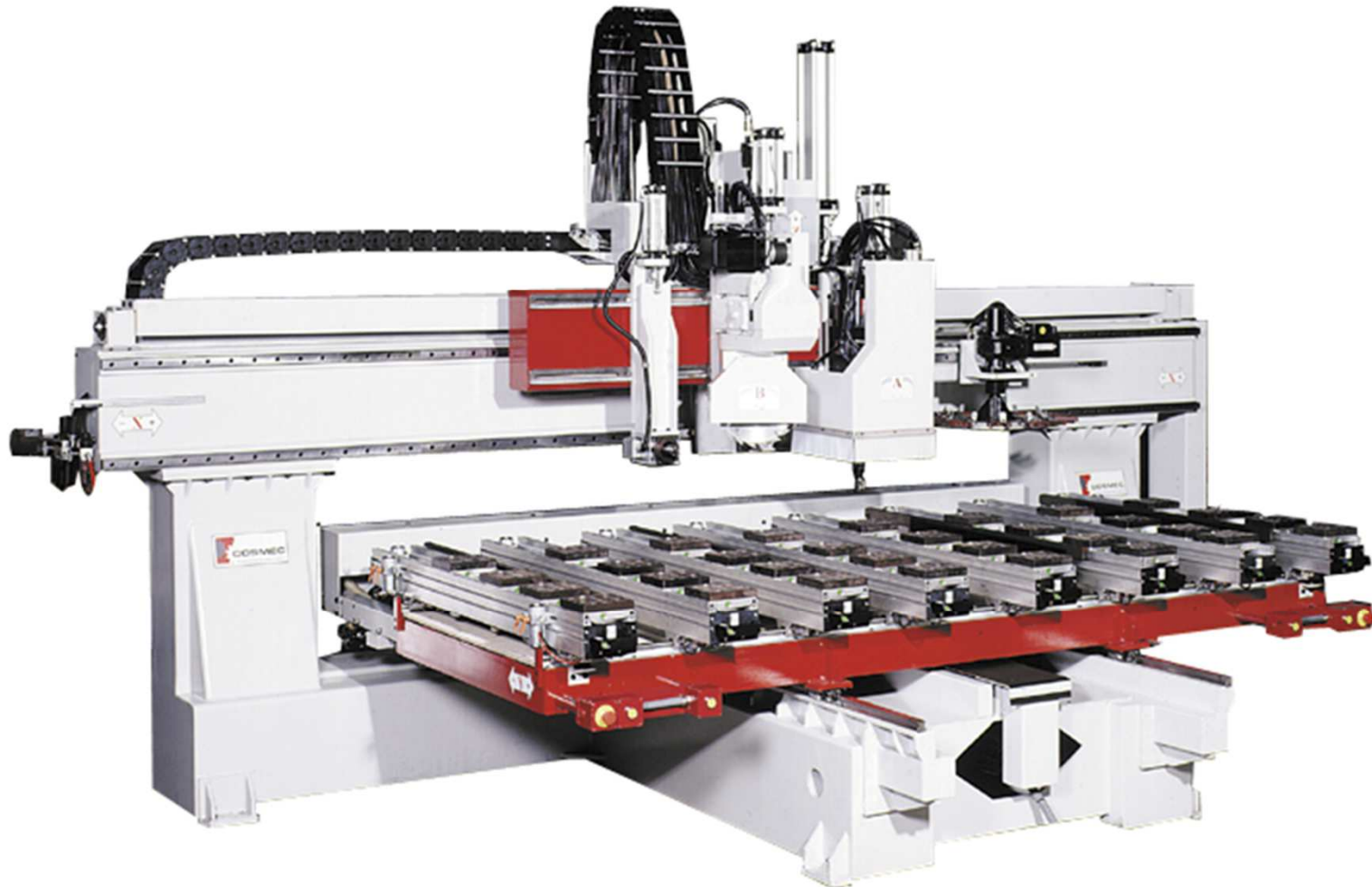



NR 3216 2P 5 + 3 AXIS HEADS WITH PODS & RAILS





**NR 3216 2P PALLETIZED TABLE
WITH ENCLOSURE
3 AXIS + 0°/90° SAW UNIT**





NR
WITH CLOSED ENCLOSURE
WITH AUTOMATIC DOORS





NR MULTIHEADS WITH 6 TO 12 ROUTING GROUPS

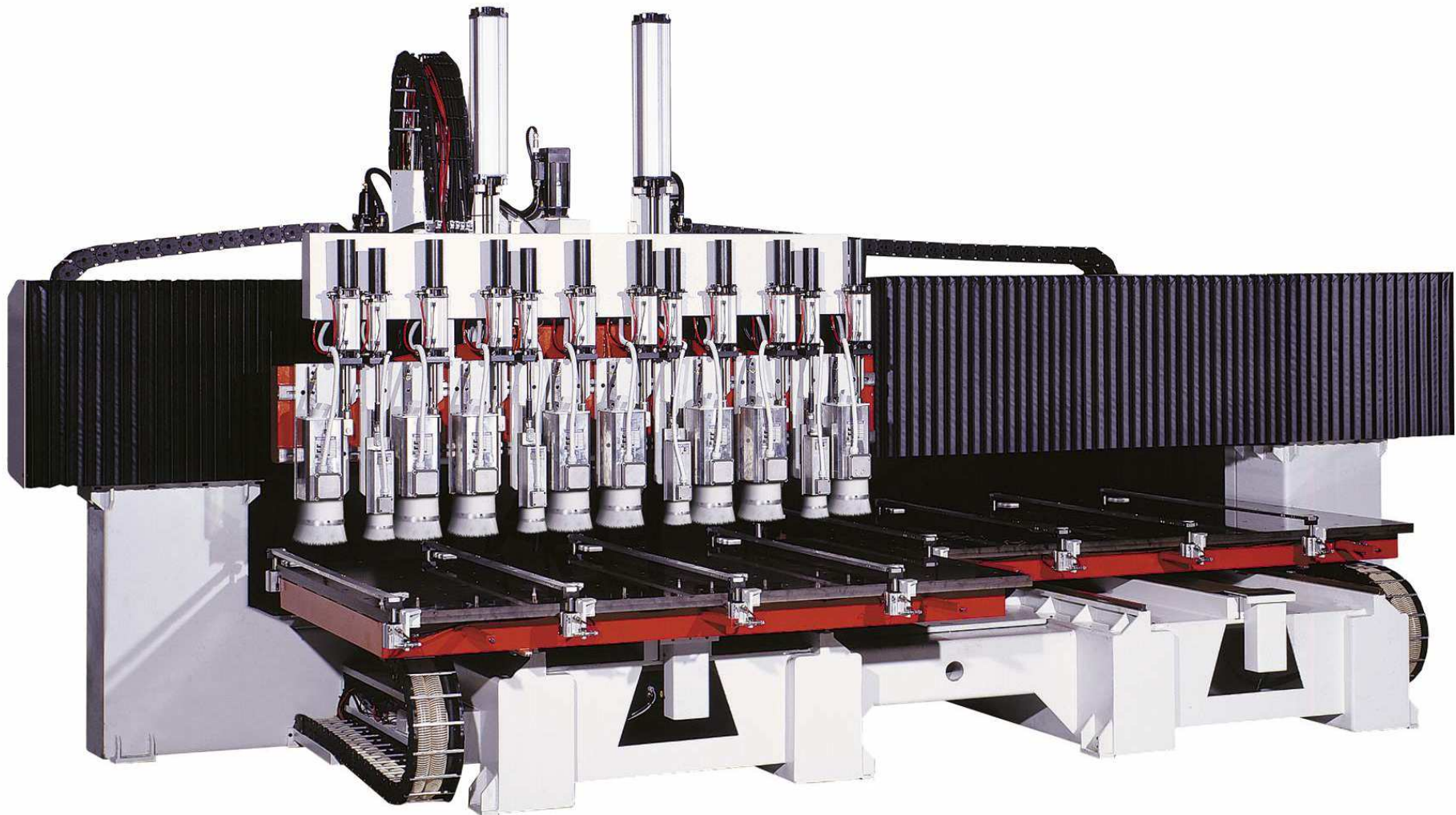



NR WITH EXTENDED TABLES STROKE

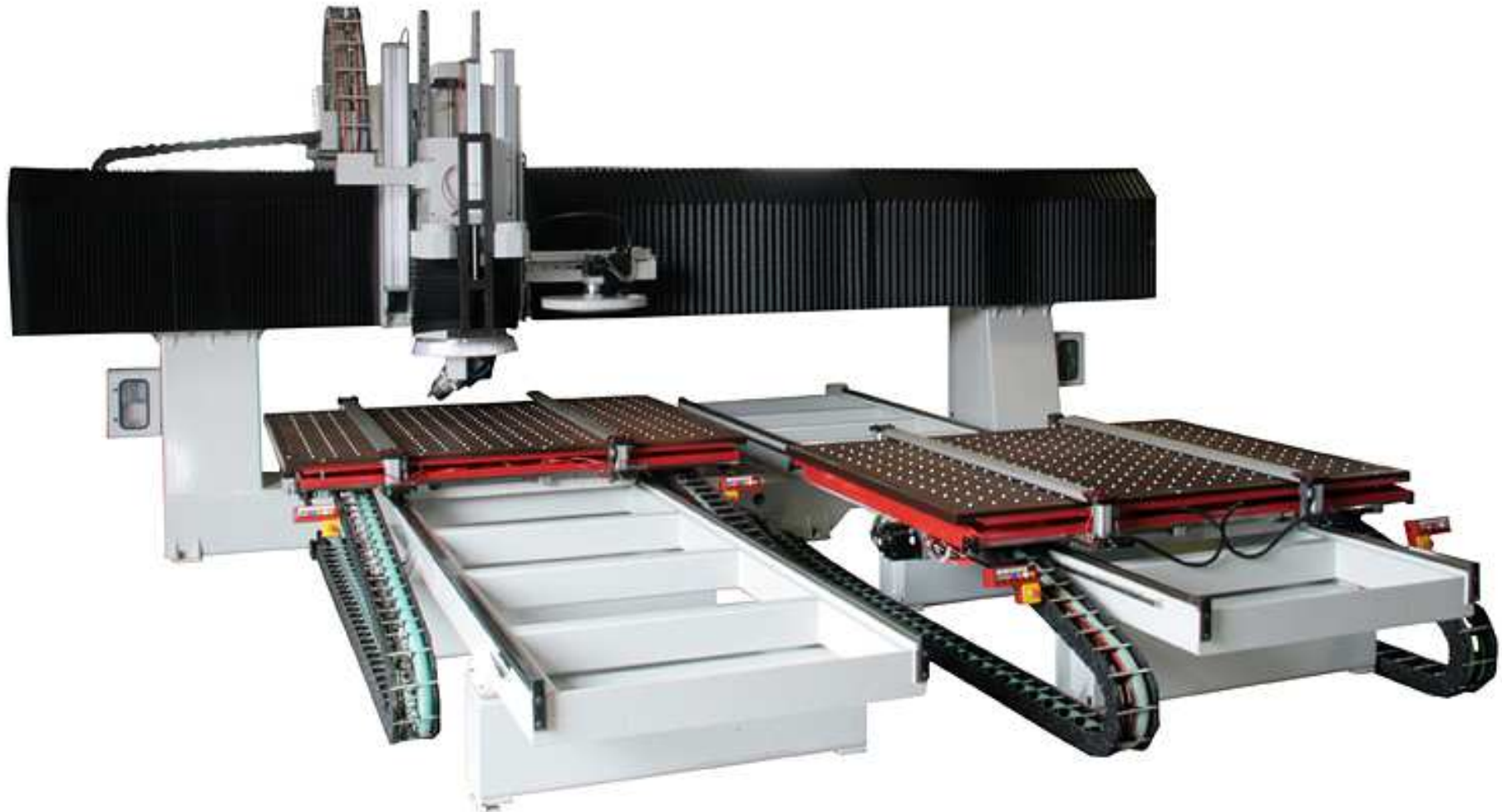



COSMEC[®]

NR TWIN HEADS IN THE SAME MACHINE WITH A ROBOT TO LOAD AND UNLOAD IN THE MIDDLE





NR
WITH ALUMINIUM TABLE
5 AXIS
Z 1200 mm

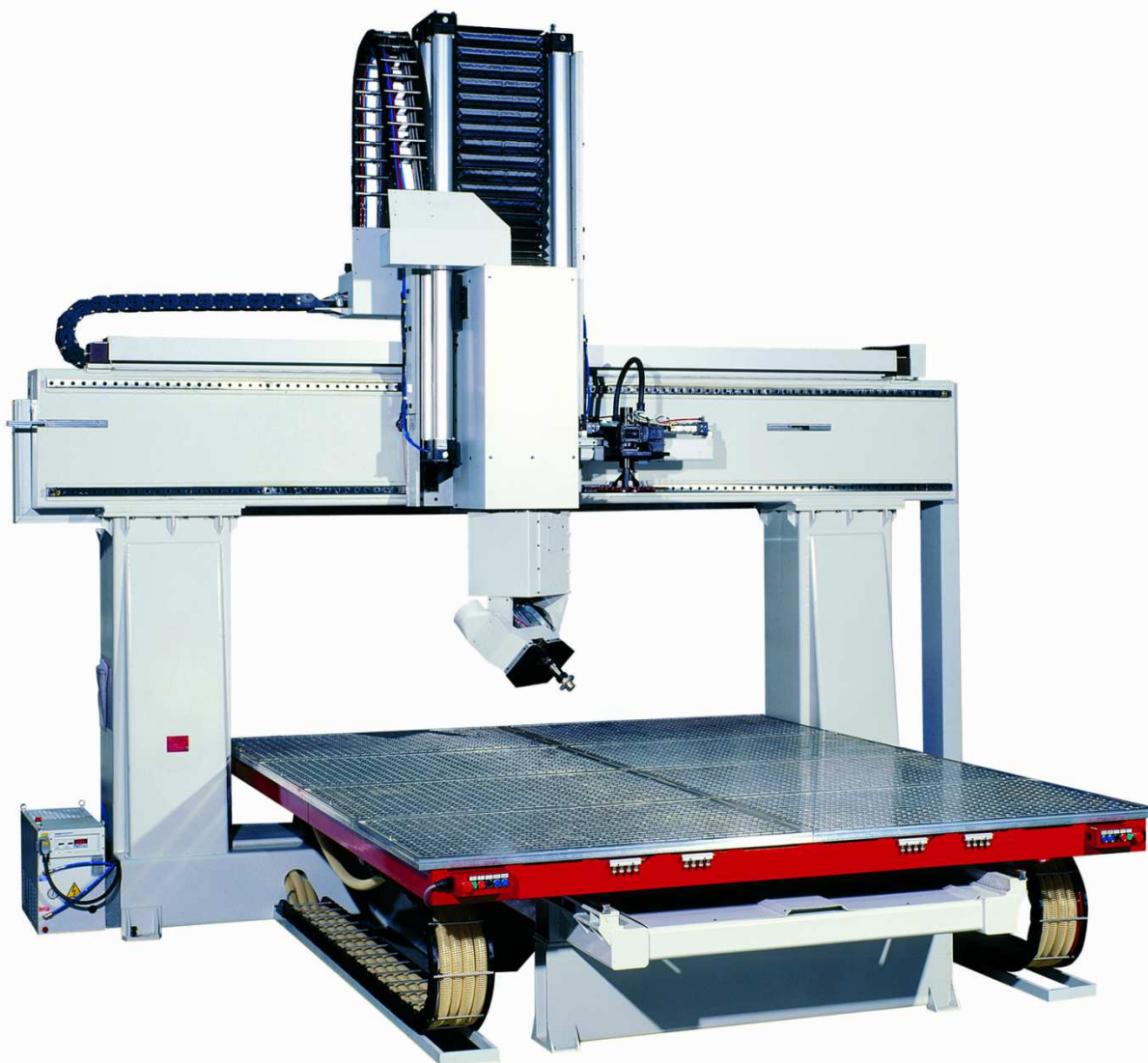



NR
WITH 5 AXIS HEAD
AND ROTATING PLATE
AS 6TH AXIS





NR
WITH PALLETIZED TABLES
TILTING PARALLEL HEADS
Z FROM 500 TO 1200 mm





NR
WITH 2 INDEPENDENT
5 AXIS HEADS
SPECIALLY MADE FOR
ALUMINIUM INDUSTRY





NR PF
FOR TRUCKS, VANS AND
CARAVAN INDUSTRY FROM
8200 x 2800 TO
15000 x 4000 mm
WORKING TABLE
AUTOMATIC LOADING AND
UNLOADING

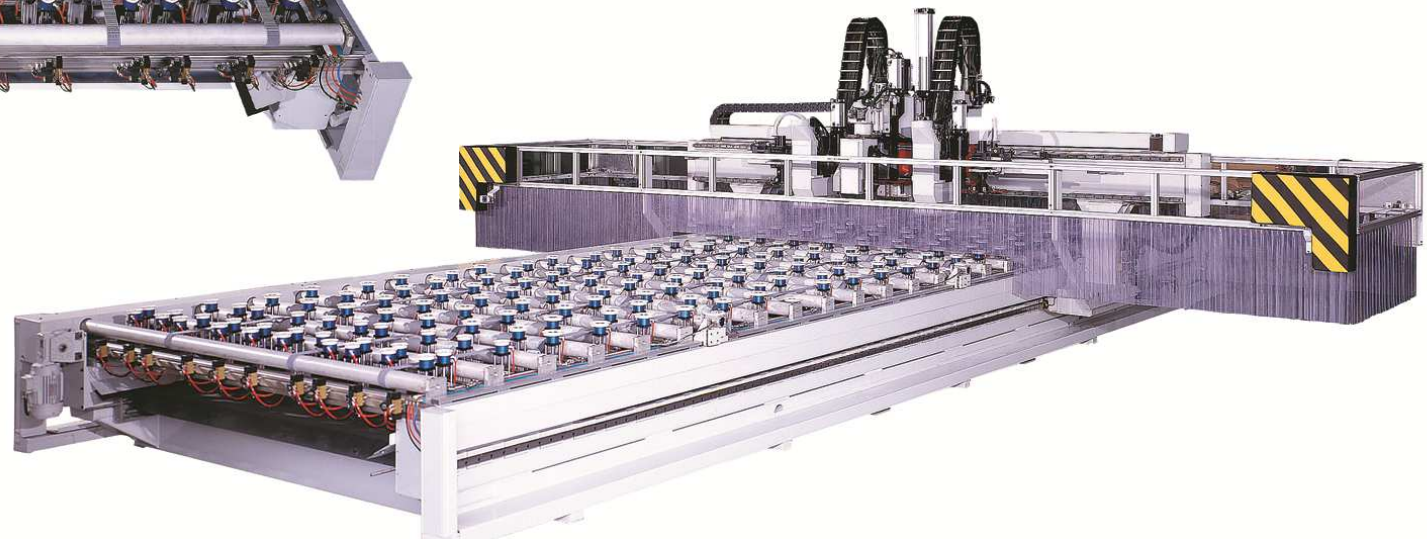
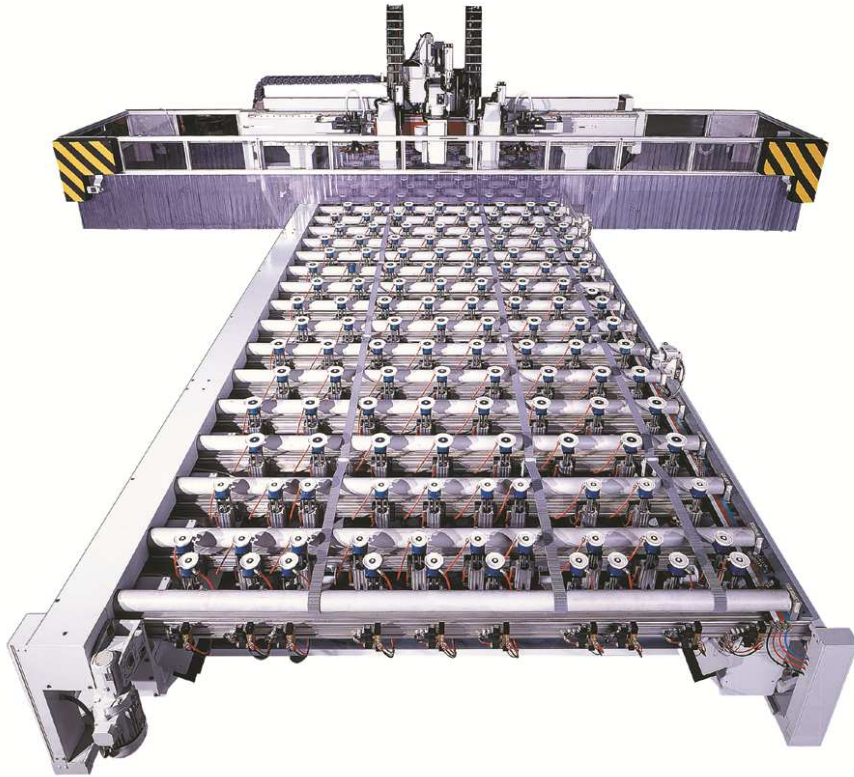



NR PF
FROM 8200 X 2800 TO 15000 X 4000
WORKING TABLE
IN BAKELITE

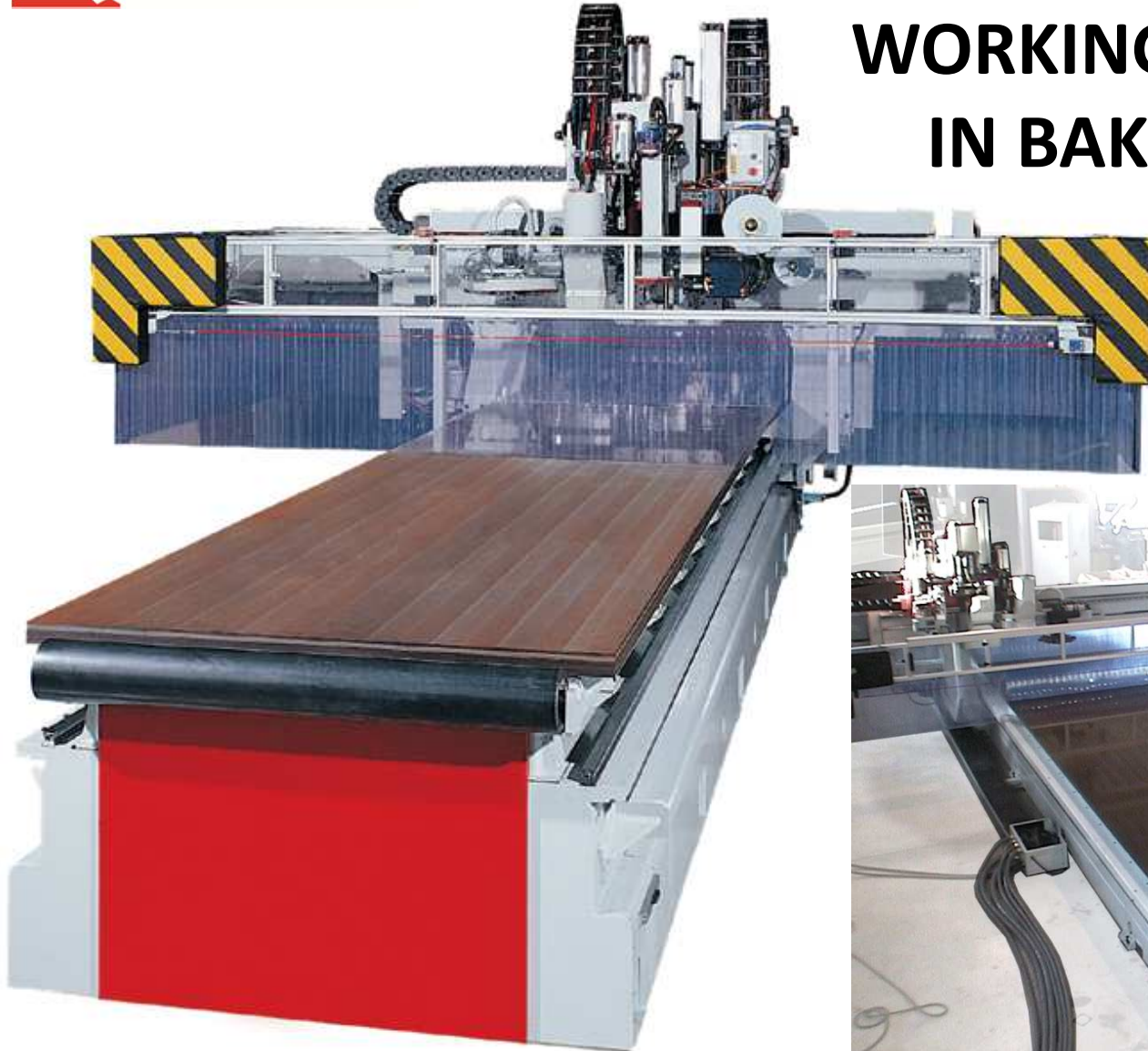



NR
5 AXIS





NR
2 X 5 AXIS





**NR
WITH TELESCOPIC
5 AXIS
TO SAVE HEIGHT**





NR
4 AND 3 AXIS HEADS + SAW UNIT
AND CNC CONTROLLED
SIDE FENCES

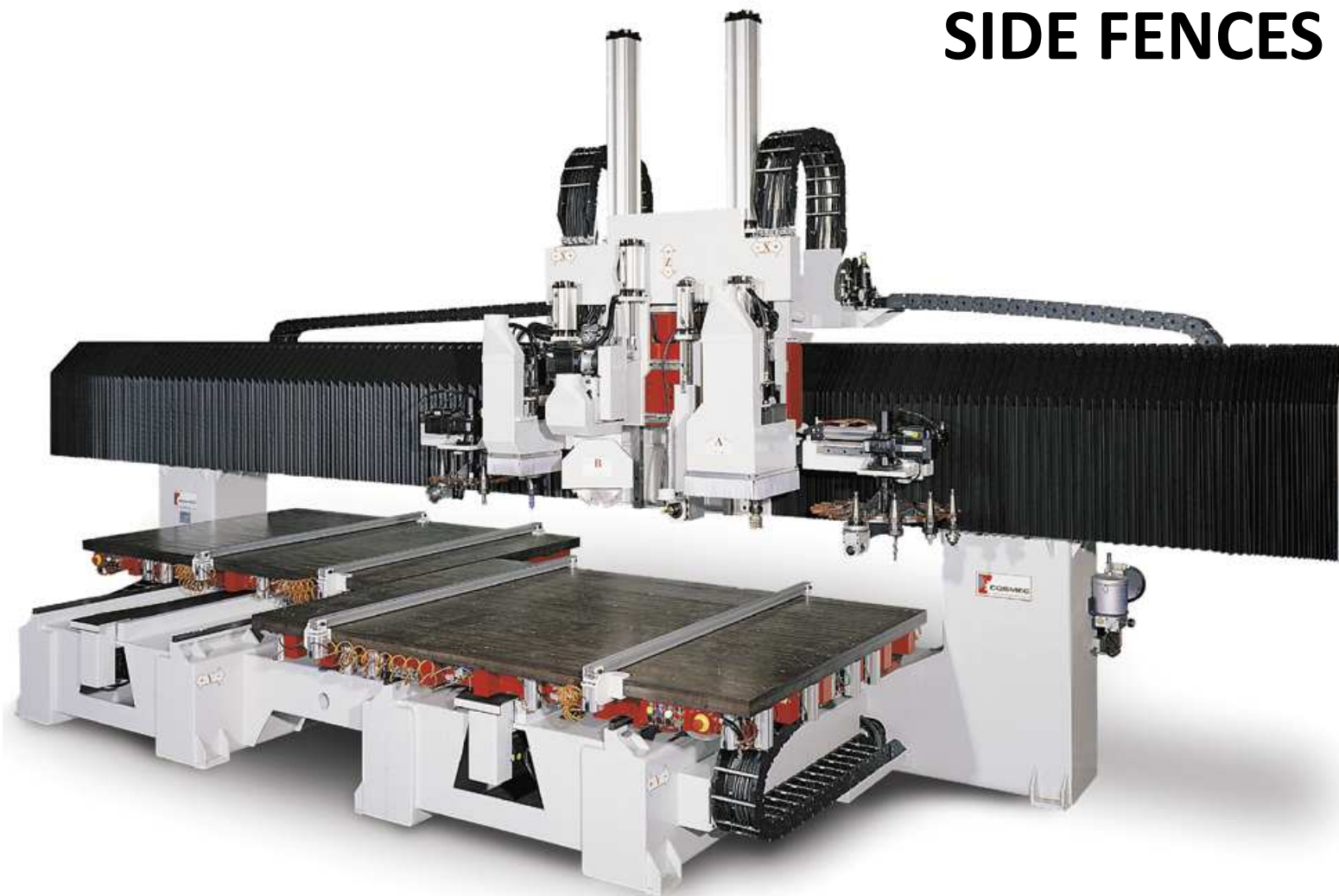



NR PF WITH 5 AXIS AND 7 X 3 AXIS HEADS

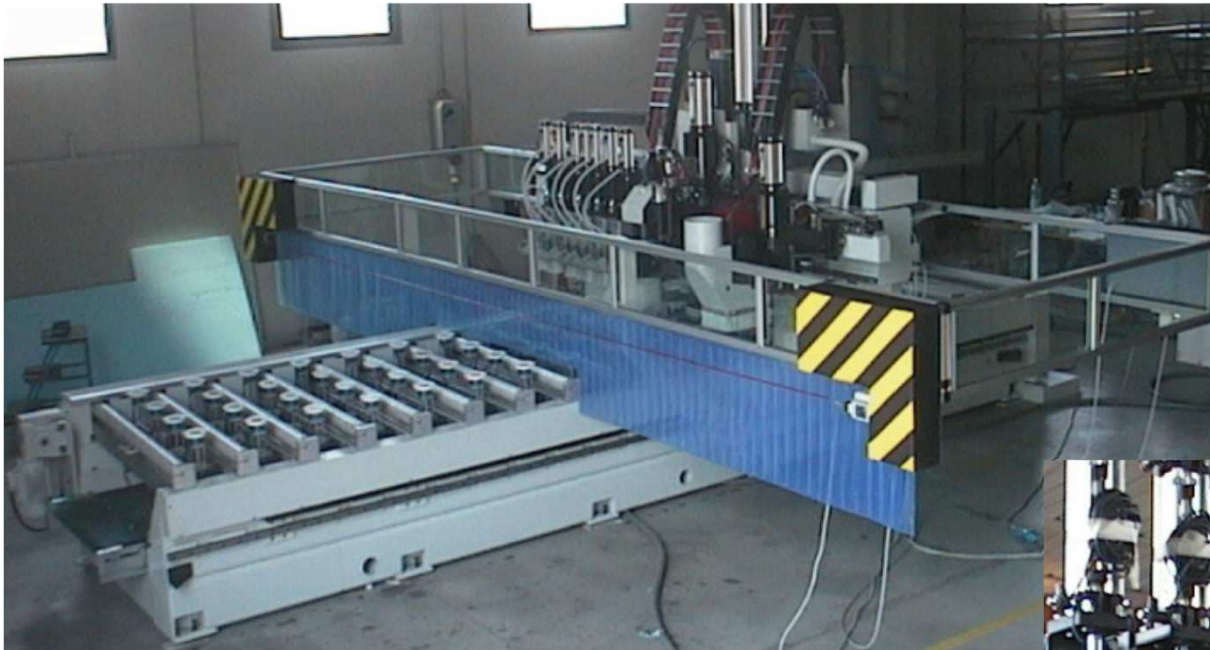



NR 2 X 4 AXIS + 2 X DRILLING UNITS

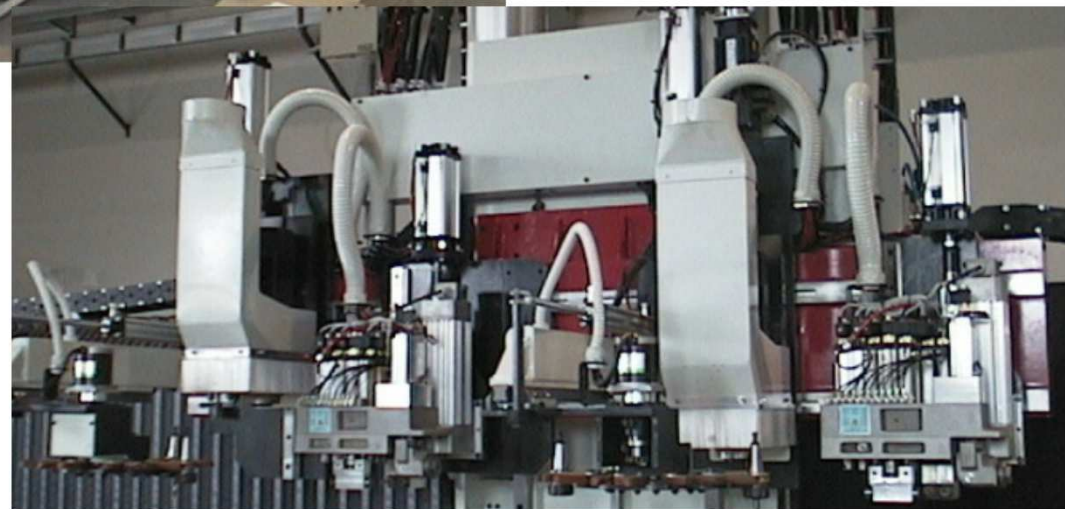



NR WITH SPECIAL WORKING TABLE WITH 3 ROUTERS





NR FOR CARPENTRY JOINING, LOG HOUSE, PREFABRICATED HOUSE

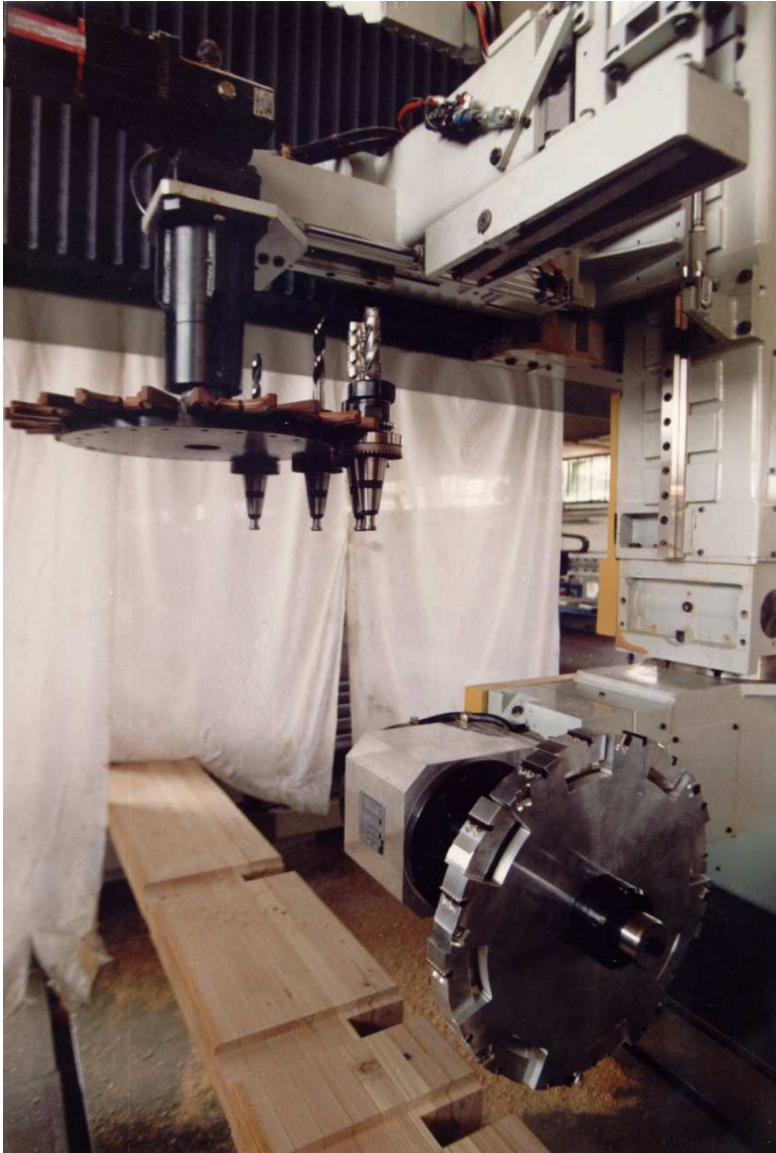



NR WITH MULTIPLE HEADS ALSO WITH DISAXED HEADS





NR

1 X HORIZONTAL ROUTER

4 X BORING GROUPS

7 X 12 KW ROUTERS

8 X 5 KW ROUTERS





NR WITH MULTIPLE HEADS ALSO WITH DISAXED HEADS





NR 4 + 3 AXIS HEADS



CONQUEST «RIDE»
ONE SIDE : ROUTER + LABEL
PRINTER + VACUUM PRESS
OTHER SIDE: 360° SAW UNIT +
BORING GROUP





NR PF MOTORHOMES, CARAVANS, TRUCKS, VANS, PRODUCTION





NR
2 X TILTING HEADS
1 X 360° SAW UNIT
1 X BORING GROUP
1 X 4 HORIZONTAL
EXITS UNIT



NR & CONQUEST
3, 4, 5, 6 AXIS ROUTERS
90°, 360° TURNING SAW UNITS
FROM 2,2 TO 20 KW ROUTERS
FROM 3 TO 44 DRILLING SPINDLES UNITS





NR & CONQUEST CUSTOMIZED SOLUTIONS FOR WORK SMALL AND BIG PIECES AND TAILOR MADE JIGS, CLAMPINGS AND SUPPORTS

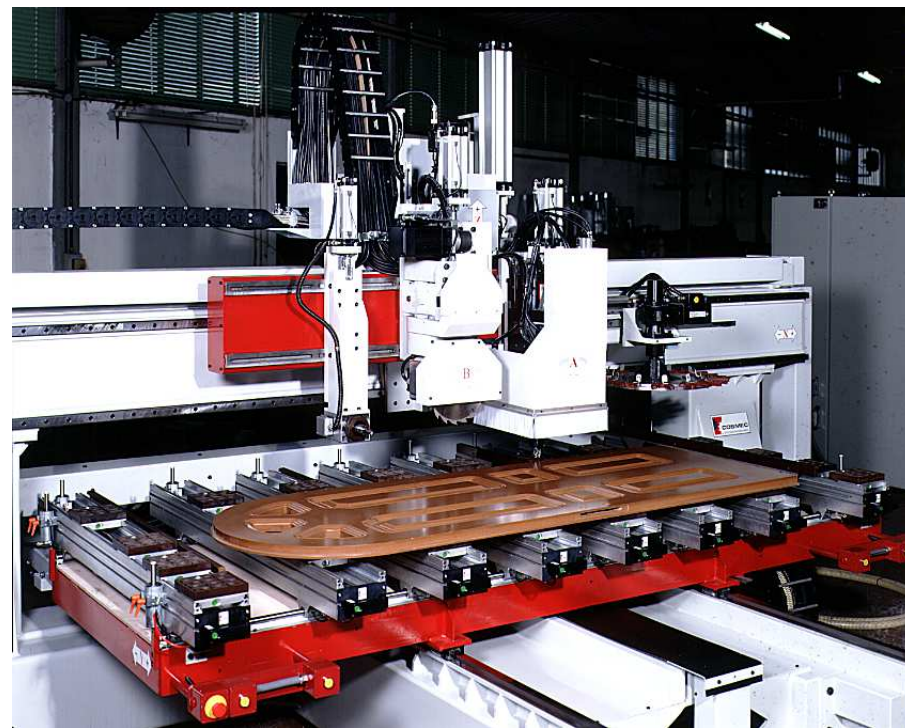



NR 4 AND 3 AXIS HEADS + SAW UNIT AND CNC CONTROLLED SIDE FENCES





NR & CONQUEST CAN WORK ANY SORT OF PIECE





NR & CONQUEST SPECIAL JIGS FOR WOOD, ALUMINIUM AND SPECIAL MATERIALS AS COMPOSITES AND FOAMS

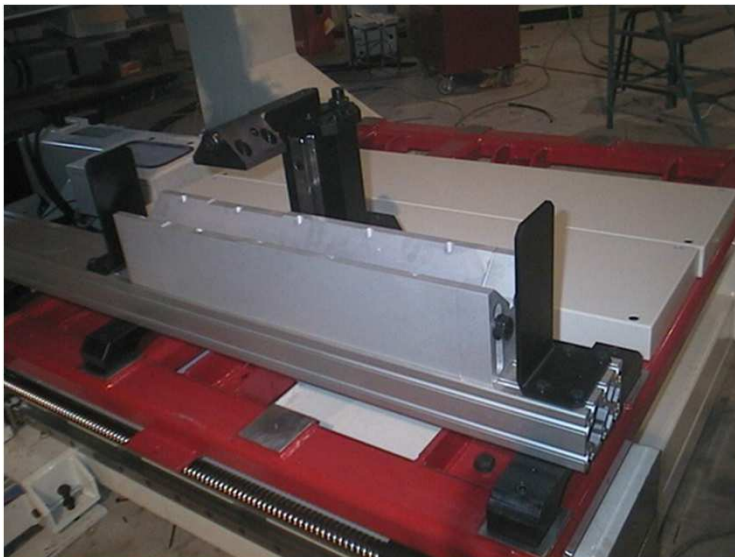
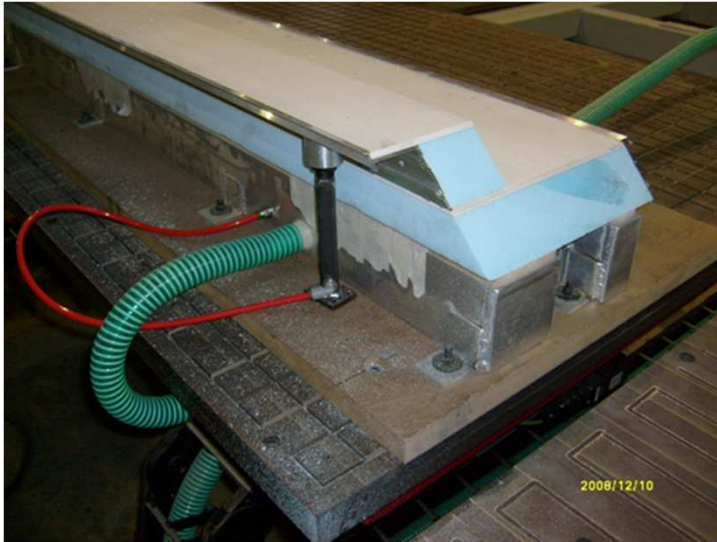



NR AN HUGE VARIETY OF SPECIAL CLAMPING SYSTEMS

